

**Notes**

- Digit scanning is MSD first (ØD2 occurs before ØD1).
- Ø1 is 136 KHz, number cycle is Ø1/4/15 = 566 Hz.
- Capacitance in microfarads unless otherwise specified.
- Manufacture: Olympia Werke AG (West Germany) (Made in Japan).
- This drawing based on unit with Serial No. 0428711. IC in this unit datecoded 7403.
- 2000 May 05: Initial drawing / bhilpert.  
2020 Feb: Format updates / bh.

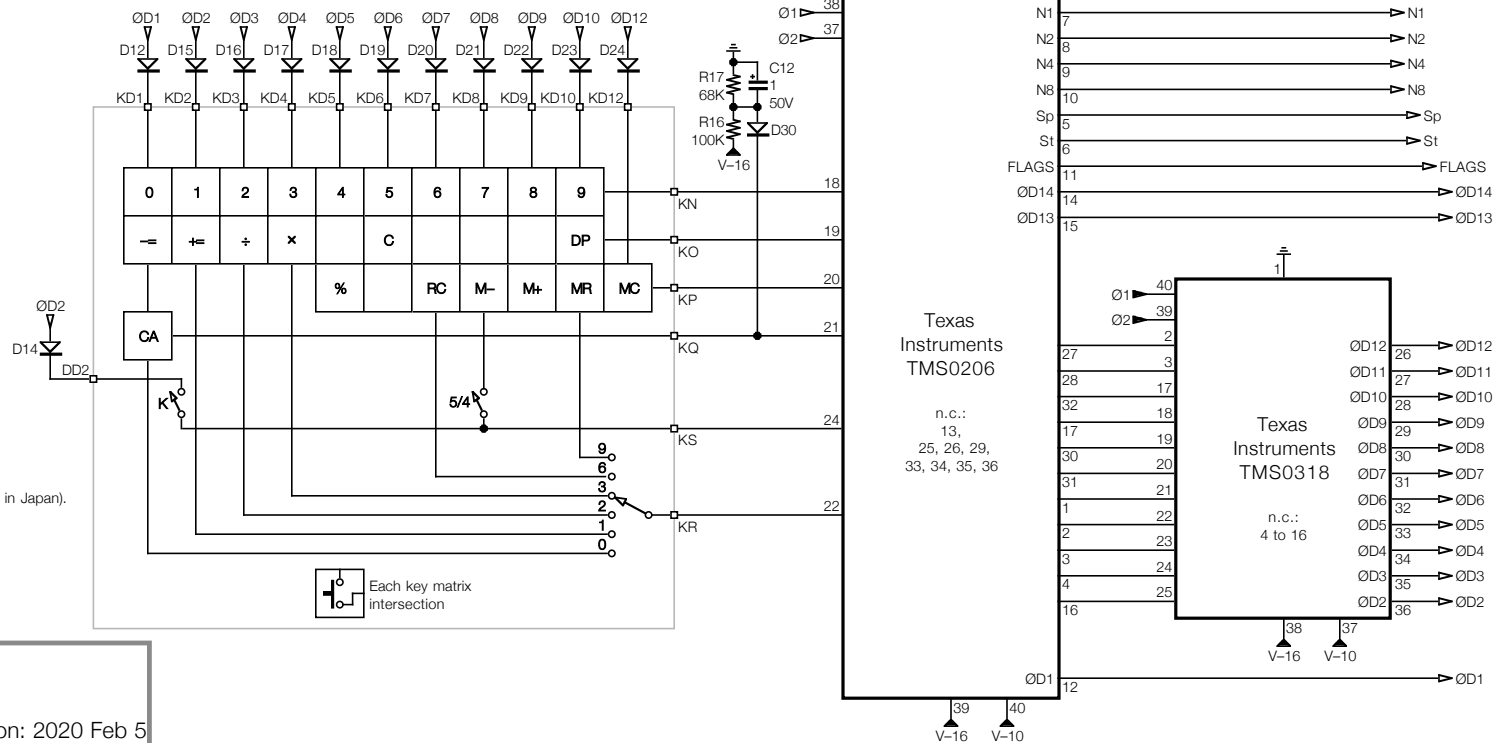

**Olympia CD401A  
Calculator**

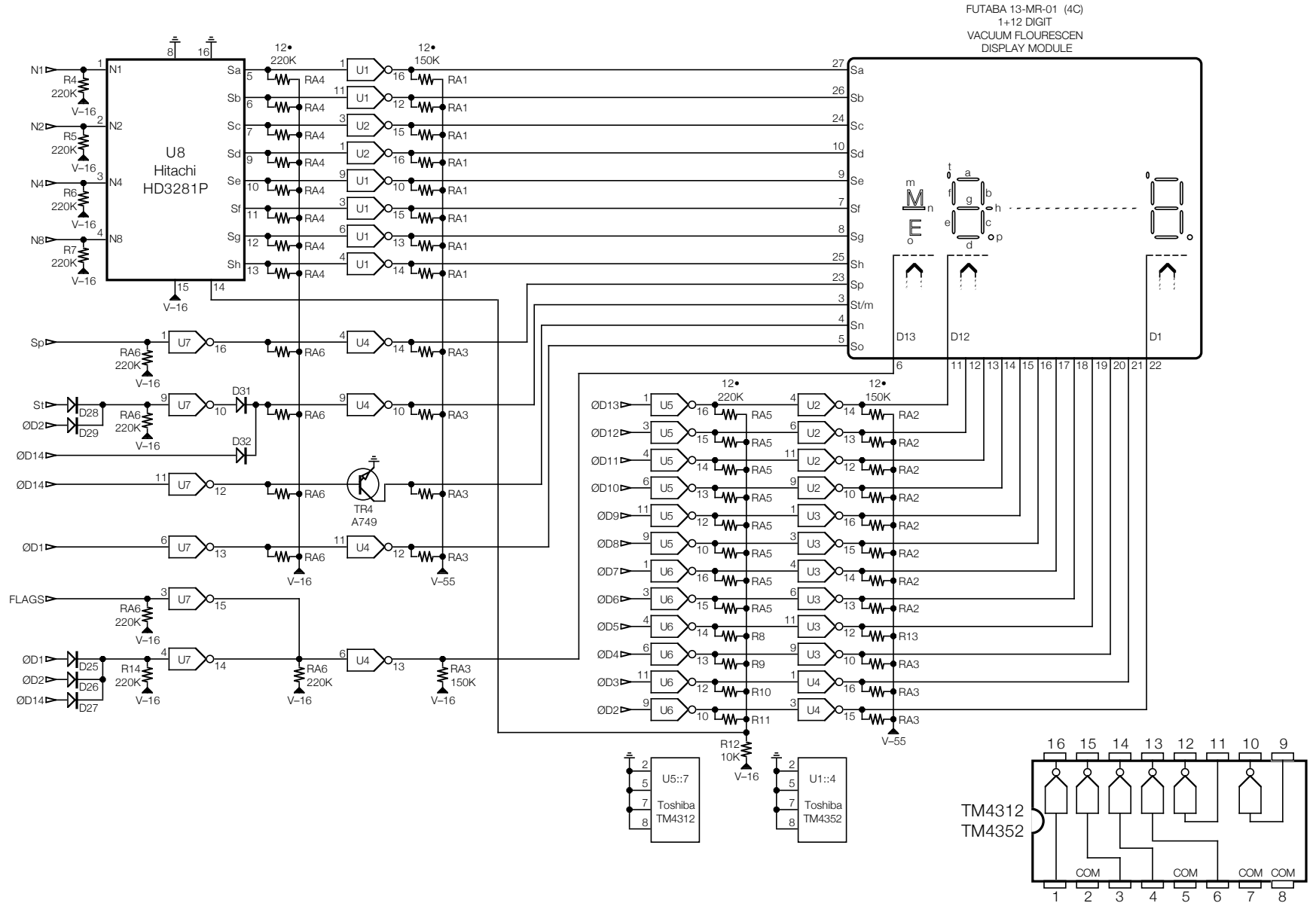

Olympia CD401A  
Calculator

